



ANS Conference



Conference on Nuclear Training and Education

CONTE 2017 Official Program

A Biennial International Forum

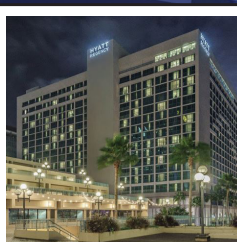

February 5-8, 2017
Hyatt Regency Riverfront
Jacksonville, FL



ANS

CONTE 2017

Conference on Nuclear Training and Education

*Our most sincere thanks to our sponsors for their support of the 2017
CONTE Conference on Nuclear Training and Education*

PLATINUM SPONSORS



GOLD SPONSORS



SILVER SPONSORS



BRONZE SPONSORS



Table of Contents

GENERAL MEETING INFORMATION

| | |
|---------------------------|-----|
| Meeting Officials | 4 |
| Daily Schedule | 5-7 |
| General Information | 8-9 |
| Technology Expo | 8 |

PLENARY, SPECIAL SESSIONS & EVENTS

| | |
|--|----|
| NUCP | 10 |
| Super Bowl Opening Reception | 10 |
| Opening Plenary | 10 |
| Monday Afternoon Plenary & Awards Luncheon | 10 |
| Monday Evening Reception | 11 |
| Tuesday Afternoon Plenary & Luncheon | 11 |
| Tuesday Evening Reception | 11 |
| Closing Plenary & Luncheon | 11 |

CONTE 2017 TECHNICAL SESSIONS

| | |
|--|-------|
| Technical Sessions by Day: Monday | 12-14 |
| Technical Sessions by Day: Tuesday | 15-19 |
| Technical Sessions by Day: Wednesday | 20-22 |

TECHNOLOGY EXPO

| | |
|------------------------------|-------|
| Exhibitor Listing | 23 |
| Exhibit Hall Floorplan | 23 |
| Exhibitor Descriptions | 24-26 |

ADDITIONAL

| | |
|------------------------|----|
| Hotel Floorplans | 27 |
|------------------------|----|

Meeting Officials

A Biennial International Forum

2017 Conference on Nuclear Training and Education



GENERAL CHAIR

Julie Sickle
Exelon Nuclear

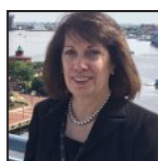

TECHNICAL PROGRAM CO-CHAIR

Dr. Jane LeClair
Washington Center for Cybersecurity R&D



TECHNICAL PROGRAM CO-CHAIR

Michael Desilets
Entergy Nuclear

TECHNICAL COMMITTEE

Dr. Sukesh Aghara
University of Massachusetts-Lowell

Dr. Philip Beeley
Khalifa University

Elizabeth McAndrew-Benavides
NEI

Patrick Berry
Patrick Berry Consulting, LLC

Dr. Oum Bouhelal
Higher National School "Mines-Rabat" Morocco

Dr. Gilbert Brown
Independent Consultant

Dr. Richard Coe
Thomas Edison State University

Heather Davis
Exelon Nuclear

Jose Luis Delgado Criado
Tecnatom

Dave Drury
IAEA

David Helling
Westinghouse

Chris Hynes
Duke Energy

Dr. Michael Johnson
Excelsior College

Tammy Love
INPO

Michael Marler
Accelerant Solutions

Lisa Marshall
North Carolina State University

Brian O'Donnell
INPO

Andrew Padilla
Sandia National Laboratories

Robert Sandstrom
Accelerant Solutions





Dr. Irina Vorobeva
*Obninsk Institute for Nuclear Power Engineering of the
National Research Nuclear University MEPhI*

Daily Schedule

Sunday, February 5

| | | |
|----------------|---|------------------------------------|
| 4:30 – 8:00 pm | Registration | Grand Foyer (2nd Level) |
| 5:00 – 6:30 pm | NUCP Partners Orientation (Invitation Only) | River Terrace (3rd Level) |
| 6:30 – 9:00 pm | Opening Reception in the Expo: Super Bowl Sunday Sponsored by:  | Expo Hall (Grand Foyer, 2nd Level) |

Monday, February 6

| | | |
|--------------------|---|------------------------------------|
| 7:00 am – 5:00 pm | Registration | Grand Foyer (2nd Level) |
| 7:00 am – 6:30 pm | Technology Expo | Expo Hall (Grand Foyer, 2nd Level) |
| 7:00 – 8:00 am | Breakfast in Technology Expo | Expo Hall (Grand Foyer, 2nd Level) |
| 8:00 – 9:00 am | Opening Plenary: A Biennial International Forum | Grand 4, 5 (2nd Level) |
| 9:00 – 9:30 am | AM Break in Technology Expo <i>Sponsored by:</i>  | Expo Hall (Grand Foyer, 2nd Level) |
| 9:30 – 11:10 am | Technical Sessions: • Personnel Training/Qualification—I | Grand 6 (2nd Level) |
| 9:30 – 11:10 am | • Engineering Training and Education—I | Grand 7 (2nd Level) |
| 9:30 am – 8:30 pm | NUCP Summit Sessions & Events | Clearwater (3rd Level) |
| 11:30 am – 1:00 pm | Afternoon Plenary & Awards Luncheon <i>Sponsored by:</i>  | Grand 4, 5 (2nd Level) |
| 1:00 – 2:20 pm | Technical Sessions: • IAEA Capacity Building/Workforce Development | Grand 6 (2nd Level) |
| 1:00 – 2:40 pm | • Operator Licensing/Training Operator Fundamentals—I | Grand 7 (2nd Level) |
| 2:30 – 3:00 pm | PM Break in Technology Expo <i>Sponsored by:</i>  | Expo Hall (Grand Foyer, 2nd Level) |
| 3:00 – 4:45 pm | Technical Sessions • CYBER SECURITY—How to Train the Nuclear Workforce on Cybersecurity –Panel | Grand 6 (2nd Level) |
| 3:00 – 4:40 pm | • Simulators/Simulation | Grand 7 (2nd Level) |
| 3:00 – 4:20 pm | • Instructional Design and Development—I | Grand 8 (2nd Level) |
| 5:00 – 6:30 pm | Monday Evening Reception <i>Sponsored by:</i>  | Expo Hall (Grand Foyer, 2nd Level) |

Daily Schedule

Tuesday, February 7

| | | |
|--------------------|---|------------------------------------|
| 7:00 am – 5:00 pm | Registration | Expo Hall (Grand Foyer, 2nd Level) |
| 7:00 am – 6:30 pm | Technology Expo | Expo Hall (Grand Foyer, 2nd Level) |
| 7:00 – 8:00 am | Breakfast in Technology Expo | Expo Hall (Grand Foyer, 2nd Level) |
| 8:00 – 9:45 am | Technical Sessions: <ul style="list-style-type: none"> • International Benchmarking of Training Cost Reduction Efforts–Panel | Grand 6 (2nd Level) |
| 8:00 – 9:20 am | <ul style="list-style-type: none"> • Operator Licensing/Training Operator Fundamentals—II | Grand 7 (2nd Level) |
| 8:00 – 9:20 am | <ul style="list-style-type: none"> • Personnel Training/Qualification—II | Grand 8 (2nd Level) |
| 9:30 – 10:00 am | AM Break in Technology Expo | Expo Hall (Grand Foyer, 2nd Level) |
| 10:00 – 11:20 am | Technical Sessions: <ul style="list-style-type: none"> • Leadership Development—I | Grand 6 (2nd Level) |
| 10:00 – 11:20 am | <ul style="list-style-type: none"> • Lessons Learned from INPO Accreditation/International Standards | Grand 7 (2nd Level) |
| 10:00 – 11:45 am | <ul style="list-style-type: none"> • Innovation in Training Materials and Programs for Nuclear Safety and Security Leadership and Culture–Panel | Grand 8 (2nd Level) |
| 11:45 am – 1:00 pm | Afternoon Plenary & Luncheon Sponsored by:  | Expo Hall (Grand Foyer, 2nd Level) |
| 1:00 – 2:30 pm | Technical Sessions: <ul style="list-style-type: none"> • Operator Training and Licensing–Panel | Grand 6 (2nd Level) |
| 1:00 – 2:20 pm | <ul style="list-style-type: none"> • Human Performance and Proficiency | Grand 7 (2nd Level) |
| 2:30 – 3:00 pm | PM Break in Technology Expo | Expo Hall (Grand Foyer, 2nd Level) |
| 3:00 – 4:45 pm | Technical Sessions: <ul style="list-style-type: none"> • U.S. Training and In-Processing Changes Driven by the “Delivering the Nuclear Promise Initiative”–Panel | Grand 6 (2nd Level) |
| 3:00 – 4:20 pm | <ul style="list-style-type: none"> • Instructional Design and Development—II | Grand 7 (2nd Level) |
| 3:00 – 4:20 pm | <ul style="list-style-type: none"> • Engineering Training and Education—II | Grand 8 (2nd Level) |
| 5:00 – 6:30 pm | Tuesday Evening Reception Sponsored by:  | Expo Hall (Grand Foyer, 2nd Level) |

Daily Schedule

Wednesday, February 8

| | | |
|--------------------|--|------------------------------------|
| 7:00 am – 12:00 pm | Registration | Expo Hall (Grand Foyer, 2nd Level) |
| 7:00 – 8:00 am | Breakfast | Grand 5 (2nd Level) |
| 8:00 – 9:30 am | Technical Sessions | Grand 6 (2nd Level) |
| 8:00 – 9:20 am | <ul style="list-style-type: none"> • International Perspectives on the Future of Nuclear Power—Panel • Operator Licensing/Training Operator Fundamentals—III | Grand 7 (2nd Level) |
| 9:30 – 10:00 am | AM Break | Grand Foyer (2nd Level) |
| 10:00-11:45 am | Technical Sessions | Grand 6 (2nd Level) |
| 10:00 – 11:00 am | <ul style="list-style-type: none"> • Enabling your Simulator Platform to Reach More Employees and Reduce Training Costs—Panel | Grand 7 (2nd Level) |
| 10:00 – 11:40 am | <ul style="list-style-type: none"> • Leadership Development—II • Cybersecurity/Training Design | Grand 8 (2nd Level) |
| 11:45 am – 1:15 pm | Closing Plenary & Luncheon | Grand 5 (2nd Level) |

FINISH YOUR DEGREE POWER YOUR CAREER

The **School of Applied Science and Technology** offers flexible, online programs designed for working adults who work in environments that benefit from technical currency, practical knowledge and applied skills.

Undergraduate Degrees

- > Nuclear Energy Engineering Technology*
- > Electronic Systems Engineering Technology*
- > Nuclear Engineering Technology
- > Nuclear Engineering Technology - Radiological Protection

*ABET Accredited



Graduate Degrees

- > Nuclear Energy Technology Management
- > Information Technology
- > Graduate certificate in Cybersecurity: Critical Infrastructure



LEARN MORE:
www.tesu.edu/astdegree
(877) 207-0576



Matthew Hayes,
BSAST '10, Nuclear
Engineering Technology

Consent To Use Photographs And Videos: All attendance of registered participants, attendees, exhibitors, sponsors and guests ("you") at American Nuclear Society ("ANS") meetings, courses, conventions, conferences, or related activities ("Events") constitutes an agreement between you and ANS regarding the use and distribution of your image, including but not limited to your name, voice and likeness ("Image"). By attending the ANS Events, you acknowledge and agree that photographs, video, and/or audio recordings may be taken of you and you grant ANS the right to use, in perpetuity, your Image in any electronic or print distribution, or by other means hereinafter created, both now and in the future, for media, art, entertainment, promotional, marketing, advertising, trade, internal use, educational purposes or any other lawful purpose. For any questions or concerns about the use of your Image, please contact the ANS Meetings & Exhibits Department at meetings@ans.org.

General Information

MEETING INFORMATION

CONTE 2017 and Technology Expo includes four days of technical programming and events. The meeting will be taking place at the Hyatt Regency Jacksonville Riverfront (225 E Coastline Dr, Jacksonville, FL 32202). The full conference fee includes admission to: Technical Sessions, Conference Proceedings, Super Bowl Reception, Breakfast and Lunches on Monday – Wednesday, and Evening Receptions on Monday and Tuesday.

REGISTRATION

ANS Registration Desk is located in the Grand Ballroom Foyer (2nd Level of the Hyatt Regency Jacksonville Riverfront). You may register, purchase additional tickets for events or pick-up your badge and registration materials during the hours listed below. Name badges must be worn during all technical sessions, in the technology expo and events. Certain events require a ticket/wristband, and may entail an additional cost for guests or 1-Day registrants.

REGISTRATION HOURS

| | |
|-----------------------|--------------------|
| Sunday, February 5 | 4:30 – 8:00 pm |
| Monday, February 6 | 7:00 am – 5:00 pm |
| Tuesday, February 7 | 7:00 am – 5:00 pm |
| Wednesday, February 8 | 7:00 am – 12:00 pm |

TECHNOLOGY EXPO & EXPO HOURS

Join us and visit with our exhibitors in the Technology Expo! Learn about new technology, products and services that are being offered. Breakfast, breaks and receptions will be hosted in the Expo. For more information or to view the floorplan and exhibitors see page 23.

| | |
|---------------------|-------------------|
| Sunday, February 5 | 6:30 – 9:00 pm |
| Monday, February 6 | 7:00 am – 6:30 pm |
| Tuesday, February 7 | 7:00 am – 6:30 pm |

ATTENDEE MEAL FUNCTIONS

Breakfast & Breaks will be provided to all registered meeting attendees, Monday – Wednesday in the Technology Expo/Grand Foyer.

Lunch will be provided to all registered meeting attendees, Monday - Wednesday. ***Please note: Lunch is a ticketed event. Tickets are included with a full meeting registration or a ticket for the corresponding day for a 1-day registration. Additional tickets are available for purchase.*

Opening Reception in the Expo- Super Bowl Sunday: This reception is a ticketed event. Heavy hors d'oeuvres and open bar are included with a full meeting registration. Additional tickets are available for purchase.

Monday & Tuesday Evening Receptions in the Technology Expo: These receptions are ticketed events. Heavy hors d'oeuvres and beverages are included with a full meeting registration. Additional tickets are available for purchase.

General Information

ABOUT ANS

Mission

ANS provides its members with opportunities for professional development. It also serves the nuclear community by creating a forum for sharing information and advancements in technology, and by engaging the public and policymakers through communication outreach.

Code of Ethics

ANS members as professionals are dedicated to improving the understanding of nuclear science and technology, appropriate applications, and potential consequences of their use. The Code of Ethics can be found at www.ans.org/about/coe.

Statement on Diversity

The American Nuclear Society (ANS) is committed, in principle and in practice, to creating a diverse and welcoming environment for everyone interested in nuclear science and technology. Diversity means creating an environment – both in ANS and in the profession – in which all members are valued equitably for their skills and abilities and respected equally for their unique perspectives and experiences. Diverse backgrounds foster unique contributions and capabilities, and so creation of an inclusive Society ultimately leads to a more creative, effective, and technically respected Society.

ANS believes that everyone deserves opportunities for learning, networking, leadership, training, recognition, volunteering in Society activities, and all the other benefits that involvement in the Society brings, regardless of age, color, creed, disability, ethnicity, gender identity and expression, marital status, military service status, national origin, parental status, physical appearance, race, religion, sex, or sexual orientation. The selection of a member to serve in ANS's volunteer leadership structure shall be based solely on the member's ability, interest and commitment to serve. In particular, ANS encourages members at each level of the Society and in each Professional Division and Technical Group to make special efforts to recruit underrepresented minorities and women to ensure that they are adequately represented in the Society.

Respectful Behavior Policy (Abbreviated)

The open exchange of ideas, freedom of thought and expression, and productive scientific debate are central to the mission of the American Nuclear Society (ANS). These require an open and diverse environment that is built on dignity and mutual respect for all participants and ANS staff members, and is free of bias and intimidation.

ANS is dedicated to providing a safe, welcoming, and productive experience for everyone participating in Society events and other Society activities regardless of age, color, creed, disability, ethnicity, gender identity and expression, marital status, military service status, national origin, parental status, physical appearance, race, religion, sex, or sexual orientation. Creation of a safe and welcoming environment is a shared responsibility held by all participants. Therefore, ANS will not tolerate harassment of or by participants (including ANS volunteer leaders and staff members) in any form. Disciplinary action for participants found to have violated this principle may include reprimand, expulsion from an event or activity with or without a refund, temporary or permanent exclusion from all ANS events and activities, suspension or expulsion from volunteer leadership positions or groups, and/or suspension or expulsion from Society membership, as appropriate.

If you or someone else experiences harassment, regardless of how you otherwise choose to initially handle the situation, you are encouraged to report the situation to ANS. It is possible that the behavior you experienced is part of a larger pattern of repeated harassment. Please alert ANS to behavior you feel to be harassment regardless of the offender's identity or standing in the Society.

The designated contact person for reports at the CONTE 2017 Meeting is ANS President Andrew C. Klein, PE during or after the event at andrew.klein@oregonstate.edu.

The complete Respectful Behavior Policy can be found at www.ans.org/about/rbp. If you have questions about the policy, please contact ANS Executive Director Robert C. Fine at 708-579-8200 or rfine@ans.org.

Plenary, Special Sessions & Events

SUNDAY, FEBRUARY 5

NUCP Partners Orientation (Invitation Only)

Location: River Terrace (3rd Level)

Time: 5:00 – 6:30 pm

Both industry and academic partners are encouraged to attend. We will review Monday's agenda, answer questions and provide time for the partnerships to mingle with the other NUCP members.

Opening Reception in the Expo: Super Bowl Sunday

Location: Expo Hall (Grand Foyer, 2nd Level)

Time: 6:30 – 9:00 pm

One ticket to the Opening Reception is included in the full meeting registration fee. Additional tickets can be purchased at the ANS Registration Desk. The reception is located in the Technology Expo (Grand Ballroom Foyer of the Hyatt Regency Jacksonville Riverfront Hotel). There will be large screen TVs, football pool, great food and drink. Sport your favorite teams colors and we hope to see you there!

Sponsored by:  Exelon Generation®

MONDAY, FEBRUARY 6

Opening Plenary Session: “A Biennial International Forum”

Location: Grand 4, 5 (2nd Level)

Time: 8:00-9:00 am

Plenary Speakers:

- Dr. Andrew Klein, ANS President
 - Lawrence G. Jones, Past President of ABET and former Principal Researcher at the Software Engineering Institute (SEI) of Carnegie Mellon University
-

Afternoon Plenary & Awards Luncheon

Location: Grand 4, 5 (2nd Level)

Time: 11:30 am – 1:00 pm

Presentation of the Dr. Robert Long Training Excellence Award: *For Leadership and a Continuing Sustained Commitment to Excellence in Nuclear Training and Education both in the US and Internationally.*

- Presented to: Gilbert J. Brown, University of Massachusetts Lowell
- Presented to: Larry R. Foulke, University of Pittsburgh

Plenary Speaker:

- Dr. Dohee Hahn, Director of the Division of Nuclear Power, Department of Energy at the IAEA

Sponsored by:  DUKE ENERGY®

Plenary, Special Sessions & Events

MONDAY, FEBRUARY 6

Evening Reception

Location: Expo Hall (Grand Foyer, 2nd Level)

Time: 5:00 – 6:30 pm

One ticket to the Monday Reception is included in the full meeting registration fee. Additional tickets can be purchased at the ANS Registration Desk. The reception is located in the Technology Expo (Grand Ballroom Foyer of the Hyatt Regency Jacksonville Riverfront Hotel).

Sponsored by:  Westinghouse

TUESDAY, FEBRUARY 7

Afternoon Plenary & Luncheon

Location: Grand 4, 5 (2nd Level)

Time: 11:45 am – 1:00 pm

Plenary Speaker:

- Honorable Stephen G. Burns, 16th Chairman of the NRC

Sponsored by:  Entergy Nuclear Excellence
We Power Life

Evening Reception

Location: Expo Hall (Grand Foyer, 2nd Level)

Time: 5:00 – 6:30 pm

One ticket to the Tuesday Reception is included in the full meeting registration fee. Additional tickets can be purchased at the ANS Registration Desk. The reception is located in the Technology Expo (Grand Ballroom Foyer of the Hyatt Regency Jacksonville Riverfront Hotel).

Sponsored by:  TVA

WEDNESDAY, FEBRUARY 8

Closing Plenary & Luncheon

Location: Grand 5 (2nd Level)

Time: 11:45 am – 1:15 pm

Plenary Speaker:

- Kim Maza, Vice President, Workforce Training, Education and Proficiency, Institute of Nuclear Power Operations

MONDAY, FEBRUARY 6

TECHNICAL SESSIONS - 9:30 AM

Personnel Training/Qualification—I

Session Organizers and Chairs: Michael L. Marler (*Accelerant Solutions*), Robert Sandstrom (*Accelerant Solutions*)

Location: Grand 6 **Time:** 9:30-11:10 am

9:30 am

Computer Based Emergency Operating Procedures in the Classroom and Simulator, Robert W. McDonald (*Inst for Energy Technology*)

9:50 am

RCNET: A Bridge between Academia and the Nuclear Industry, Kevin Cooper (*Indian River State College*), James Auld (*NextEra Energy Co.*)

10:10 am

Personality Factors that Predict Initial License Candidate Success, Cynthia DeVita-Cochrane (*DCE Assessments*)

10:30 am

On Demand Video (ODV) Training, Doug James Barber (*Xcel Energy*)

10:50 am

Refurbishment Outages: Regulatory Oversight to Ensure Workers' Competencies, Thomas Manning, Pascale Bourassa (*Canadian Nuclear Safety Commission*)

Engineering Training and Education—I

Session Organizers and Chairs: Michael C. Johnson (*Excelsior Coll*), Heather Davis (*Exelon Nuclear*)

Location: Grand 7 **Time:** 9:30-11:10 am

9:30 am

Advanced Reactor Operations Laboratory Course, Clive H. Townsend, Robert S. Bean (*Purdue Univ*)

9:50 am

Reaching the Public with a Nuclear MOOC, L. R. Foulke (*Univ of Pittsburgh*)

10:10 am

SC State Nuclear Engineering Program: Two-Year College Students adds Fuel to the Four-Year Program, April Hutton-Moorer, Kenneth C. Okafor (*SC State Univ*)

10:30 am

Reinforcing the Fundamentals of Graduate Nuclear Engineering Through Game-Based Learning, Daniel G. Cole (*Univ of Pittsburgh*), Brittany Butler, Cheryl A. Bodnar (*Rowan Univ*), Renee M. Clark, Jesse Davis, Tom Congedo (*Univ of Pittsburgh*)

10:50 am

Engineering Training Using Cyber (Desk Top) Simulator, Bryan E. Holcomb, Dan F. MacNeal (*Exelon*)

Technical
Sessions:
Monday
February
6

MONDAY, FEBRUARY 6

TECHNICAL SESSIONS - 1:00 PM

IAEA Capacity Building/Workforce Development

Session Organizers and Chairs: Lisa M. Marshall (*NC State University*), David Drury (*IAEA*)

Location: Grand 6 **Time:** 1:00-2:20 pm

1:00 pm

Suggestions of Nuclear Knowledge Sharing Program for Newcomers with the Korea's Knowledge Sharing Program, Hansuk Ko, Byungchul Shin, WoongKi Kim, (*KAERI*)

1:20 pm

Key Issues Addressing the Introduction of Nuclear Power as a Sustainable Alternative, Oum Keltoum Bouhelal (*ENIM*)

1:40 pm

Strategies for International Academic and Research Cooperation, Dmitrii Samokhin (*National Research Nuclear Univ*), invited

2:00 pm

10 Years' Experience of U.S.-Russia Universities Cooperation on Human Resource Development for the Safe and Effective Utilization of Nuclear Energy, Irina Vorobeva (*Obninsk Inst. for Nucl.Pwr. Engineering of MEPHI*)

Operator Licensing/Training Operator Fundamentals—I

Session Organizers and Chairs: Patrick J. Berry (*Patrick Berry Consulting, LLC*), Jose Delgado (*Tec-natom*)

Location: Grand 7 **Time:** 1:00-2:40 pm

1:00 pm

A Simplified Fission Product Poison Model for Operator Training, James E. Stracener, Bruce R. Hugo (*Energy Northwest*)

1:20 pm

More Success in Fundamental Operator Training Through Examinations, Gary Sanford (*E3 Services LLC*)

1:40 pm

Using Technology to Enhance Nuclear Learning and Knowledge Retention, Bernard Gagnon (*L-3 Communications MAPPS Inc.*)

2:00 pm

Next Generation Simulator Critiques/Operator Fundamentals Database, Matthew McMullin, Chris Dahlman (*TVA - Sequoyah*)

2:20 pm

Control Room GlassTop Simulators, Robert Felker, Mark Terry, Dmitry Gavrilov, Dmitry Barkovsky, Svetlana Postnikova (*Western Services Corp.*)

Technical
Sessions:
Monday
February
6

MONDAY, FEBRUARY 6

TECHNICAL SESSIONS - 3:00 PM

CYBER SECURITY—How to Train the Nuclear Workforce on Cybersecurity—Panel

Session Organizer and Chair: Jane A. LeClair (*Washington Center for Cybersecurity R&D*)

Location: Grand 6 **Time:** 3:00-4:45 pm

The Cyber Security of our critical infrastructure is one of the most important topics in the Nuclear Sector. Today's prospective graduates are gaining momentum in the exciting field of Nuclear Cyber Security and there is a distinct need to have highly trained personnel implementing and ensuring defense-in-depth protection strategies are robust. This panel will focus on the Private and Public Sector views as to what the challenges we are facing and how students can be best prepared to support Nuclear Cyber Security.

Panelists:

Nathan Faith (*Exelon*)

Gary Garrett (*INPO*)

Scott Junkin (*Southern Co.*)

Mitch McCrory (*SNL*)

Simulators/Simulation

Session Organizers and Chairs: Michael Desilets (*Entergy Nuclear*), Robert Sandstrom (*Accelerant Solutions*)

Location: Grand 7 **Time:** 3:00-4:40 pm

3:00 pm

Simulator Fidelity, Impact on Operations, Glenn Krause (*Entergy*)

3:20 pm

Seeing, Practicing and Understanding by Doing-Simulation, the Most Effective Way to Learn, Richard P. Coe (*Thomas Edison State Univ*)

3:40 pm

Recent Post-Fukushima Simulator Updates, Vincent Gagnon (*L-3 Communications MAPPS Inc.*)

4:00 pm

Integration of GPWR Simulation Laboratory in Teaching, Research and Outreach, Jason Hou, Kostadin Ivanov, Lisa Marshall (*NC State Univ*); Sean Fuller, Jay Umholtz (*GSE Systems*)

4:20 pm

Restoring the V.C. Summer Flow Simulator Problems and Solutions, Jody Hosteler (*SCANA*)

Instructional Design and Development—I

Session Organizers and Chairs: Vincent Andrew Padilla (*SNL*), Tammy Love (*INPO*)

Location: Grand 8 **Time:** 3:00-4:20 pm

3:00 pm

Short Simulator Scenarios and Video Critiques to Improve Operator Performance, Mark Similey (*Duke Energy*)

3:20 pm

Motivating Integration of Technology and Innovation into Training at Exelon, Steven Minya (*Exelon*)

3:40 pm

Using SACADA to Support Crew Simulator Performance Improvement, Shawn W. St. Germain (*INL*), James Chang (*NRC*), Todd Madary (*STPNOC*)

4:00 pm

The Use of Non-Nuclear Industry Events in Training, Bert Barnes (*Exelon Nuclear, Nine Mile Point Station*)

Technical Sessions: Monday February 6

TUESDAY, FEBRUARY 7

TECHNICAL SESSIONS - 8:00 AM

International Benchmarking of Training Cost Reduction Efforts—Panel

Session Organizer and Chair: David Drury (*IAEA*)

Location: Grand 6 **Time:** 8:00-9:45 am

Open discussion between U.S. and international training professionals on what they are doing to reduce training costs. Notes will be collected and shared amongst the international training community on best practices and actions that can be taken to reduce training cost at nuclear facilities.

Panelists:

Mike Hogben (*Lockhead Martin UK*)

Phil Robinson (*EDF Energy*)

Francisco Sánchez (*Tecnatom*)

Callum Thomas (*Thomas Thor Associates EU*)

Operator Licensing/Training Operator Fundamentals—II

Session Organizers and Chairs: David Helling (*Westinghouse*), Chris Hynes (*Duke Energy*)

Location: Grand 7 **Time:** 8:00-9:20 am

8:00 am

Operations Training Staff Augmentation at Exelon, R. J. Frederes (*Exelon*)

8:20 am

Three Option Examination, Glenn Macdonald (*Accelerant Solutions LLC*)

8:40 am

New Build Reactor Plant Reference Simulator Upgrade Process, D. E. Spielman (*Southern Nuclear*)

9:00 am

New Construction Initial License Exam, M. L. McCue (*Southern Nuclear*)

Personnel Training/Qualification—II

Session Organizers and Chairs: Gilbert J. Brown (*Independent Consultant*), Michael Desilets (*Entergy Nuclear*)

Location: Grand 8 **Time:** 8:00-9:20 am

8:00 am

Using STEs to Improve Personnel Performance and Reduce Training Cost, Patricia Wade (*EPRI*), Burl McCosh (*OpX Consulting*), Michael Jessen (*Entergy Nuclear*)

8:20 am

Interactive 3D Simulation and Radiation Visualization for Training Field Workers, Espen Nystad, István Szöke, George McCullough, Grete Rindahl (*IFE*)

8:40 am

Training Staffing and Qualifications Performance Indicator, Robert Cameron (*Exelon*)

9:00 am

A 'Quick and Easy' Approach to Continuous Skill Assessment, Alexandra Fernandes, Maren Eitheim, Robert McDonald (*IFE*)

Technical
Sessions:
Tuesday
February
7

Technical
Sessions:
Tuesday
February
7

TUESDAY, FEBRUARY 7

TECHNICAL SESSIONS - 10:00 AM

Leadership Development—I

Session Organizers and Chairs: Tammy Love (*INPO*), Michael Desilets (*Entergy Nuclear*)

Location: Grand 6 **Time:** 10:00-11:20 am

10:00 am

Entergy's Leadership Development Programs—The Power to Learn, Aileen M. Nethery (*Entergy*)

10:20 am

The Role of Higher Education in Developing Teamwork Skills, Sean M. Riley (*Excelsior Coll*)

10:40 am

The Importance of Educating Potential Leaders on Organizational Communication Theory, Raymond Dean (*Excelsior Coll*)

11:00 am

Tuesday's in Training, James Tsardakas (*Exelon*)

Lessons Learned from INPO Accreditation/International Standards

Session Organizer and Chair: David Drury (*IAEA*)

Location: Grand 7 **Time:** 10:00-11:40 am

10:00 am

SOTrain Feedback Enterprise Application, Angela DiLillo, Brian Reed (*Southern Nuclear Operating Co.- Plant Farley*)

10:20 am

Evolution of Training Accreditation in the United Kingdom, Philip Robinson (*EDF Energy*)

10:40 am

Self-Assessment Data Collection, Report Generation and Analysis at Exelon, Kerry Wright, Terrence Smith (*Exelon*)

11:00 am

Development of an Evidence-Based Accreditation Self-Evaluation Report, William W. Thompson (*Accelerant Solutions, LLC and William Thompson Consulting, LLC*)

11:20 am

INPO Accreditation—Update on Recent Changes, Elery M. (Rusty) Shoemaker (*INPO*)

Innovation in Training Materials and Programs for Nuclear Safety and Security Leadership and Culture—Panel

Session Organizer and Chair: Oum Keltoum Aziza Bouhelal (*EMR Engineering School of Mines*)

Location: Grand 8 **Time:** 10:00-11:45 am

The panel will discuss innovative methods and strategies used to develop training materials and programs for nuclear safety and security to show the importance of intensive exchange and experience in training practices that build security leadership and culture.

Panelists:

Jason Harris (*Purdue University*)

Ingrid Kirsten (*WINS Academy*)

Jane LeClair (*Washington Center for Cybersecurity R&D*)

Lisa Marshall (*NC State University*)

TUESDAY, FEBRUARY 7

TECHNICAL SESSIONS - 1:00 PM

Operator Training and Licensing–Panel

Session Organizer and Chair: Patrick J. Berry (*Patrick Berry Consulting, LLC*)

Location: Grand 6 **Time:** 1:00-2:30 pm

This panel will include key members of the NRC, INPO and Industry who will participate in a discussion fueled by a question and answer format. Participants will have open-forum access to the panel to address issues, questions, concerns and challenges related to the topical area.

Panelists:

Andy Barbee (*SCANA*)

Gregg Ludlam (*Exelon*)

Maurin Scheetz (*NRC*)

Chuck Sizemore (*NextEra Energy*)

Human Performance and Proficiency

Session Organizers and Chairs: Lisa M. Marshall (*NC State University*), Robert Sandstrom (*Accelerant Solutions*)

Location: Grand 7 **Time:** 1:00-2:00 pm

1:00 pm

Human Performance Meets Performance Analysis, Jennifer L. Yunk (*WCNOC*)

1:20 pm

Nuclear Security and Safety Education Program at the Higher National School of Mines-Rabat, Oum Keltoum Aziza Bouhelal (*ENSMR*)

1:40 pm

Knowledge Management Impacts on Organizational Proficiency and Ultimately Performance, D. Heler (*Nuclear Human Resources Group*), R. Sandstrom (*Accelerant Solutions*)

Technical
Sessions:
Tuesday
February
7

TUESDAY, FEBRUARY 7

TECHNICAL SESSIONS - 3:00 PM

U.S. Training and In-Processing Changes Driven by the “Delivering the Nuclear Promise Initiative”—Panel

Session Organizer and Chair: Patrick Berry (*Patrick Berry Consulting, LLC*)

Location: Grand 6 **Time:** 3:00-4:45 pm

Presentation for international CONTE participants and IAEA webinar subscribers to learn about the changes being conducted in the USA to streamline training and education process and reduce training costs. Participants will be able to ask U.S. experts questions on the initiative and dive into details on what the USA is doing on topics like: the Systematic Approach to Training, operator training, leadership training, engineering initial and continuing training, in-processing training, distance learning and use of common and transportable qualifications.

Panelists:

James Caery (*Entergy Nuclear*)

Marios Kafantaris (*MCK Consulting, LLC*)

Rusty Shoemaker (*INPO*)

Tom Van Wyen (*Exelon Nuclear*)

Instructional Design and Development—II

Session Organizers and Chairs: Vincent Andrew Padilla (*SNL*), Tammy Love (*INPO*)

Location: Grand 7 **Time:** 3:00-4:20 pm

3:00 pm

Proficiency Challenges and Solutions using VISION, Michael Marler (*Accelerant Solutions LLC*)

3:20 pm

Improving Performance through Training in the Affective Domain, Kent K. Peckham (*TVA*)

3:40 pm

Setting Up a Room to Cater to Online Learners’ Needs, Christophe Demazière, Peter Apell, Christian Stöhr, Tom Adawi (*Chalmers Univ of Techn*)

4:00 pm

Cost Saving Options for Accrediting Technical Training Programs, Peter M. Knoetgen (*Accelerant Solutions LLC*)

TUESDAY, FEBRUARY 7
TECHNICAL SESSIONS - 3:00 PM

Engineering Training and Education—II

Session Organizers and Chairs: Michael C. Johnson (*Excelsior Coll*), Heather Davis (*Exelon Nuclear*)

Location: Grand 8 **Time:** 3:00-4:20 pm

3:00 pm

Improving Equipment Reliability through Training at Calvert Cliffs, Peter Beavers (*Exelon*)

3:20 pm

Utilizing Plant Simulator Technology in Online Nuclear Technology Degree Programs, Sean M. Riley (*Excelsior Coll*)

3:40 pm

Hands-on Experiment Training Program for Nuclear Engineering Students at KAERI, Byungchul Shin, Jongyeol Won, Woongki Kim (*KAERI*)

4:00 pm

FLEX Training for Engineers and Program Owners, Robyn L. Brixey (*Rob Brixey, Inc.*)

Technical Sessions:
Tuesday
February
7

UNIVERSITY OF PITTSBURGH | SWANSON SCHOOL OF ENGINEERING

come home to
Pitt's Graduate Online Engineering Programs

Available relevant programs include:

- MS Nuclear Engineering
- Nuclear Engineering Certificate
- Safety Engineering Certificate

Exclusive Online Tuition and Staff Training Partnerships Available

For more information visit our booth or contact Stephanie Opalinski at stephanie.opalinski@pitt.edu

Visit Booth #18

engineering.pitt.edu/NuclearProgram

PITT | **SWANSON ENGINEERING**
GRADUATE & ONLINE PROGRAMS

WEDNESDAY, FEBRUARY 8

TECHNICAL SESSIONS - 8:00 AM

International Perspectives on the Future of Nuclear Power—Panel

Session Organizer and Chair: Jane A. LeClair (*Washington Center for Cybersecurity R&D*)

Location: Grand 6 **Time:** 8:00-9:30 am

Nearly all parts of the world today are involved in nuclear power development. With nearly 450 commercial reactors operating in over 30 countries and another 60 units under construction, there is a growing need to replace outdated fossil fuel units and meet the increased demands for electricity in the future. Learn what other countries are doing and hear these perspectives from individuals around the world.

Panelists:

Oum Bouhelal (*Higher National School 'Mines-Rabat'*)

David Drury (*IAEA*)

Demetry Samokhin (*Obninsk Inst*)

Irina Vorobeva (*Obninsk Inst*)

Operator Licensing/Training Operator Fundamentals—III

Session Organizers and Chairs: Jose Delgado (*Tecnatom*), Gilbert Brown (*Independent Consultant*)

Location: Grand 7 **Time:** 8:00-9:20 am

8:00 am

iPADS Used to Improve Exam Administration, Walter F. Smith, Jr, Tim Gabosch (*TVA WBN*)

8:20 am

Improving Initial License Training Throughput and NRC Examination Pass Rate, Donald Binkley (*Browns Ferry Nuclear Plant*)

8:40 am

Achieving Best-in-the-Nation NRC Fundamentals Exam Scores, Melnard Rio (*E3 Services, LLC*)

9:00 am

ANSI SRO Certification Management Course via Distance Learning at Exelon, Bruce Hennigan (*Exelon*)

Technical
Sessions:
Wednesday
February
8

WEDNESDAY, FEBRUARY 8

TECHNICAL SESSIONS - 10:00 AM

Enabling your Simulator Platform to Reach More Employees and Reduce Training Costs –Panel

Session Organizer and Chair: Scott Zeppelin (*GSE Systems Inc*)
Location: Grand 6 **Time:** 10:00-11:45 am

This interactive panel discussion is framed around options for increasing trainee throughput on the simulator. The discussion will investigate new methods and strategies that utilities are considering to increase capabilities, increase human performance, and reduce costs for training personnel using their “Digital Twin” - Simulator Platform. The discussion will consist of 3 panelists from 3 different utilities that have chosen 3 different solutions to addressing this issue. One panelist from Southern Company will provide the perspective of building a new Full Scope Simulator, a representative from Duke Energy will provide the perspective of building a Full Scope Virtual Glass-Top Simulator, and a representative from Ontario Power Generation will provide a perspective of using multiple VPanels in the training environment.

Panelists:

Rick Garner (*Duke, Shearon Harris*)
Bruce Hennigan (*Exelon*)
Brian Reed (*Southern Company/Plant Farley*)

Leadership Development—II

Session Organizers and Chairs: Tammy Love (*INPO*), David Helling (*Westinghouse*)
Location: Grand 7 **Time:** 10:00-11:00 am

10:00 am

Implementation of Leadership and Team Effectiveness Attributes at Exelon, Jennifer Tennis (*Exelon*)

10:20 am

New Leadership Training Program to Improve Organizational Effectiveness at Exelon, Jennifer Lawless (*Exelon*)

10:40 am

Safety Leadership: Leading Conversations that Promote Nuclear Safety, Dorothy C. Andreas, Elmo E. Collins (*O Analysis*)

Technical
Sessions:
Wednesday
February
8

WEDNESDAY, FEBRUARY 8

TECHNICAL SESSIONS - 10:00 AM

Cybersecurity/Training Design

Session Organizers and Chairs: Jane A. LeClair (*Washington Center for Cybersecurity R&D*), Richard Coe (*Thomas Edison State University*)

Location: Grand 8 **Time:** 10:00-11:20 am

10:00 am

Graduate Diploma Program in Nuclear Operation and Maintenance, George Bereznai, John Shaw (*Univ of Ontario Inst of Technology*)

10:20 am

Cybersecurity Education for the Nuclear Community, Jane LeClair (*Thomas Edison State Univ*)

10:40 am

Implementing Nuclear Security and Industry Summit Commitments on Certified Training, Daniel Johnson, Amanda Kratochvil (*World Inst for Nuclear Security*)

11:00 am

Enhancing Learning Outcomes with Online Human Performance Animations, John Nichols (*Exelon*), Kyren Miller (*Bismarck State College*)

Technical Sessions: Wednesday February 8



Advance in Your Career with Excelsior College

ABET-accredited programs:

- BS in Nuclear Engineering Technology
- BS in Electrical Engineering Technology
- BS in Information Technology

Programs aligned with NSA standards:

- BS in Cybersecurity
- MS in Cybersecurity

A National Center of Academic Excellence in
Cyber Defense Education, 2014–2019



CONTACT:

Michael Johnson, DM, faculty program director for energy management

EMAIL: MJohnson2@excelsior.edu | CALL: 518-608-8379

www.excelsior.edu



Exhibitors List

| | |
|--|--------------|
| CORYS, Inc. | Booths 11&12 |
| Excelsior College | Booth 4 |
| Exelon Generation | Booth 19 |
| Focus Learning Corporation | Booth 17 |
| GSE Systems, Inc. | Booth 22 |
| GTTSi (Global Technical Training Services, Inc.) | Booth 10 |
| Hyperspring LLC | Booth 21 |
| Institute for Energy Technology (IFE) | Booth 5 |
| L-3 MAPPS | Booth 9 |
| Maxeta Technologies | Booth 16 |
| Ontario Power Generation | Booth 1 |
| Radiation Safety & Control Services, Inc. | Booth 3 |
| TECNATOM S.A. | Booth 2 |
| Technical Training Professionals | Booth 13 |
| Teletrix | Booth 14 |
| Thomas Edison State University | Booth 15 |
| University of Pittsburgh Swanson School of Engineering | Booth 18 |
| Western Services Corporation | Booth 24 |
| Westinghouse Electric Company, LLC | Booth 6 |
| The Westwind Group, Inc. | Booth 7&8 |
| World Institute for Nuclear Security (WINS) | Booth 20 |

Exhibit Hall Floor Plan

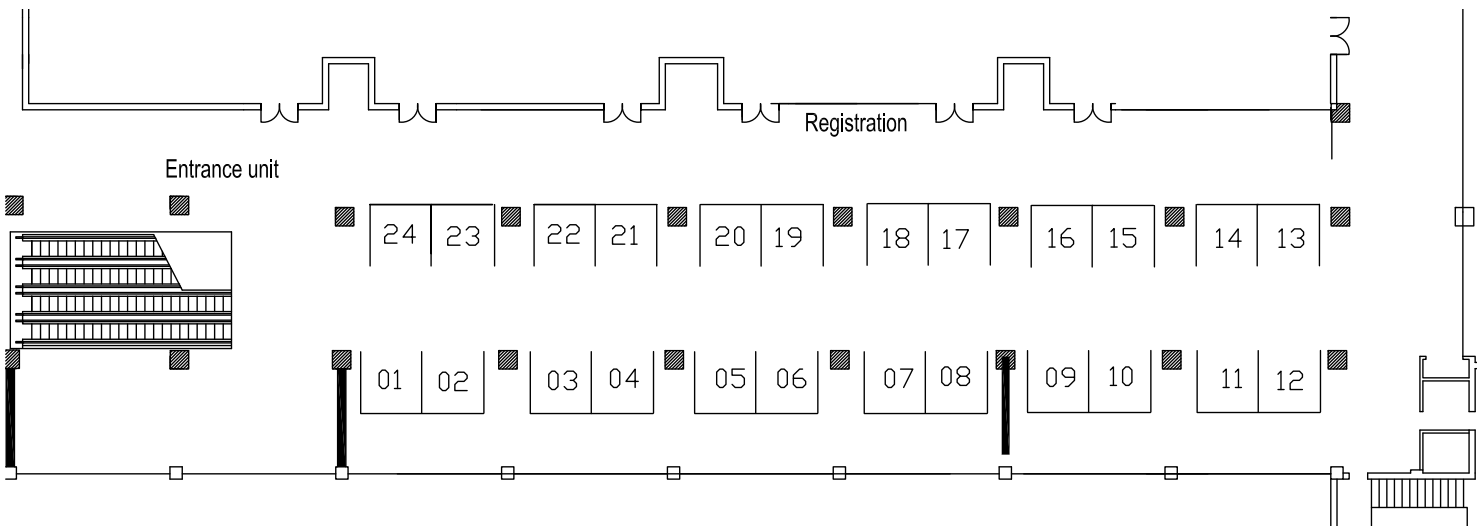

Hours

Sunday, February 5: 6:30 pm - 9:00 pm
 Monday, February 6: 7:00 am - 6:30 pm
 Tuesday, February 7: 7:00 am - 6:30 pm

Exhibitor & Expo Info

CORYS, Inc.

Jacksonville, FL (Booths 11&12)

With 180 power plant simulators delivered over the last 25 years, CORYS brings to its customers a wealth of experience. CORYS maintains more than 40 nuclear plant full scope simulators in the US and France, and provides more nuclear simulator upgrades to full scope simulators than all vendors combined.

Excelsior College

Albany, NY (Booth 4)

Excelsior's ABET accredited online BS in Nuclear Engineering Technology degree allows up to 52 credits transfer from industry training programs, and will soon open two new 15 credit concentrations: Nuclear Leadership and Nuclear Cybersecurity. Accredited by the Middle Association of Colleges and Schools, Excelsior is host to the first virtual student chapter of the American Nuclear Society.

Exelon Generation

Kennett Square, PA (Booth 19)

Exelon Nuclear, a division of Exelon Generation, operates the largest fleet of nuclear plants in America. Exelon Nuclear Training implemented fleet-wide distance learning for Maintenance Initial Training and ANSI SRO certification. The Exelon CONTE exhibit booth will provide a benchmarking opportunity to learn about this technology solution.

Focus Learning Corporation

San Luis Obispo, CA (Booth 17)

FOCUSSM Learning Corporation has provided training design services to the Department of Energy, nuclear power, aerospace and manufacturing industries where performance and safety are of paramount concern. We specialize in large training programs where complex information requirements exist. Prominent commercial and government training organizations use the system successfully to design, develop and maintain vital training programs. For more than 20 years, these organizations have provided intense, real-world testing of our unique instructional system support technology.

GSE Systems, Inc.

Baltimore, MD (Booth 22)

GSE Systems, Inc. (GSE) is a world leader in real-time simulation software that helps nuclear utilities and laboratories optimize their training with equally innovative technology and applications. Our breadth of solutions and services helps you to Deliver the Nuclear Promise of increased efficiency and excellence in safety and reliability.

GTTSi (Global Technical Training Services, Inc.)

Seneca, SC (Booth 10)

GTTSi (Global Technical Training Services, Inc.) is a leader in nuclear technical services. Since 1980, we have been a partner to 80% of US electric utilities.

GTTSi management are experts in commercial power generation. Our comprehensive range of services include; project management, training, operations support, emergency preparedness, radiation protection, environmental services, health and safety, chemistry, maintenance support, engineering, licensing, and regulatory proceedings.

Hyperspring LLC

Huntsville, AL (Booth 21)

Hyperspring LLC, a GSE Systems Company, is a comprehensive training services firm. Hyperspring personnel are industry experts using the SAT-ADDIE processes to correctly identify areas for improvement to produce individualized training solutions. Hyperspring provides services in Operations training, Engineering training, Maintenance training, and NRC Exam work. Hyperspring conducts GFE Classes and Senior Reactor Operator Certification courses to several large fleet training organizations providing both BWR & PWR Certifications.

Institute for Energy Technology (IFE)

Halden, Norway (Booth 5)

IFE is an international research foundation for energy and nuclear technology. IFE's mandate is to undertake research and development, on an ideal basis and for the benefit of society, within the energy and petroleum sector, and to carry out assignments in the field of nuclear technology for the nation.

Exhibitor & Expo Info

L-3 MAPPS

Montreal, Canada (Booth 9)

Whether supporting the existing nuclear fleet or New Build, count on L-3 MAPPS to effectively deliver a simulator solution that best suits your training or engineering needs. We offer simulators ranging from classroom trainers and system trainers to full scope simulators—all designed and aimed at unlocking value for your organization. It's our way of Delivering the Nuclear Promise!

Maxeta Technologies

Skillman, NJ (Booth 16)

Maxeta Technologies has been developing business critical software for the nuclear industry for over 15 years. Our nTAP™ software is a preparatory analysis tool that can be used to document training program self-assessments prior to an INPO Accreditation Team Visit (ATV) as well as other types of assessments.

Ontario Power Generation

Ontario, Canada (Booth 1)

As a WANO endorsed program and Ontario Power Generation and EDF Energy collaboration, the I-SNPM program is an intensive, five-week executive development program designed to develop and increase the effectiveness of senior leaders in the conduct of an executive role. International participants apply human performance principles, focus on safety and nuclear safety, and sharpen leadership and management skills through learning discussion and engagement.

Radiation Safety & Control Services, Inc.

Stratham, NH (Booth 3)

Radiation Safety & Control Services, Inc. (RSCS) is proud to demonstrate SIM-Teq™, our most advanced line of dosimeter and survey instrument training products. SIM-Teq uniquely combines both auto-response and manual control into a single solution. Trainees can master the skills necessary to properly respond to highly realistic simulated radiological situations.

TECNATOM S.A.

Madrid, Spain (Booth 2)

TECNATOM is an engineering company owned by the Spanish Electricity Utilities that provides products & services to the nuclear industry since 1957.

Its main technical capabilities are: NDT Inspection & Structural Integrity, Testing, Plant Operational Support, Training Centres, Development & Manufacture of NDT Equipment & Systems, Long Term Operation, New Comers, Safety Management and Emergency Response, carrying out projects in a wide range of technological areas for all type of reactors in more than 30 countries worldwide through their offices in France, Brazil, China, Emirates, Mexico and USA.

Technical Training Professionals

Overland Park, KS (Booth 13)

Technical Training Professionals produces state-of-the-art training materials for the utility and manufacturing industries which feature detailed 3D model images and videos. Our content can also include customization where site control screens, photos, piping and instrument drawings and other documentation are presented with our content.

Teletrix

Pittsburgh, PA (Booth 14)

Made in the USA for 25 years, Teletrix has endeavored to create innovative solutions in radiation detection training simulators. Teletrix simulators deliver superior realism in radiation detection training that effectively educate and prepare personnel to perform skillfully. Teletrix eliminates hazards of handling, transporting and exposure to radioactive materials. NEW Gas Detection Simulator!!!

Thomas Edison State University

Trenton, NJ (Booth 15)

Thomas Edison State University provides flexible, high-quality, collegiate learning opportunities for self-directed adults. The University is a pioneer in the use of the latest technologies to develop and deliver academic programs that work around the unique needs of adult learners and a national leader in the assessment of adult learning.

Exhibitor & Expo Info

University of Pittsburgh Swanson School of Engineering

Pittsburgh, PA (Booth 18)

Consistently ranked as one of the top 25 public graduate engineering programs nationally by U.S. News and World Report, our live & online masters of science & certificate options offer you the ability to specialize in a number of areas critical to today's engineering world including Nuclear Engineering. For information, please contact Stephanie Opalinski at sto24@pitt.edu.

Western Services Corporation

Frederick, MD (Booth 24)

WSC is a global simulation technology company that deploys its proprietary 3KEYSOFTWARE® Simulation Technology for nuclear training simulators and to support engineering design and commissioning of new plants in the US, Korea, China and the UAE. WSC has a vigorous market-focused R&D program and a strong commitment to customer service.

Westinghouse Electric Company, LLC

Madison, PA (Booth 6)

Westinghouse Electric Company is the world's leading supplier of safe and innovative nuclear technology. We provide our utility customers around the world with the most reliable, dependable nuclear power plants, nuclear fuel, plant automation and operating plant products and services. At Westinghouse, we are solely focused on nuclear energy technology. Our goal is simple--to provide solutions to our customers to keep their plants safe, reliable and efficient.

The Westwind Group, Inc.

Wilmington, NC (Booth 7&8)

The Westwind Group, Inc. mission is to equip our domestic and international clients with solutions that measurably contribute to productivity & continuous improvement in the work place.

WWG specializes in all areas of training & performance support solutions (including accreditation renewal management), technical & information technology services, project management and management support services, including EPU projects. We have extensive experience and our managers and consultants can provide services that result in turnkey solutions or be engaged on a staff augmentation basis.

World Institute for Nuclear Security (WINS)

Vienna, Austria (Booth 20)

WINS offers the world's first international certification programme for nuclear security management. Our aim is to support the industry's leading practitioners as they take their place at the forefront of new professional requirements for nuclear security competence, leading to more effective and financially efficient security options.

SAVE THE DATE:

Nuclear and Emerging Technologies for Space 2017 (NETS)

Cape Canaveral, FL
February 27 – March 2, 2017
REGISTRATION IS OPEN AT ANS.ORG

International High-Level Radioactive Waste Management (IHLRWM 2017)

Charlotte, NC
April 9 -13, 2017
REGISTRATION IS OPEN AT ANS.ORG

2017 ANS Student Conference

Pittsburgh, PA
April 6 – 9, 2017
REGISTRATION IS OPEN AT ANS.ORG

2017 ANS Annual Meeting (Embedded with the 10th International Topical Meeting on Nuclear Plant Instrumentation, Control and Human Machine Interface Technologies & Expo (NPIC-HMIT))

San Francisco, CA
June 11 – 15, 2017
REGISTRATION WILL OPEN IN FEBRUARY AT ANS.ORG

13th International Topical Meeting on Nuclear Applications of Accelerators (AccApp'17)

Quebec City, Quebec, Canada
July 31 –August 4, 2017
REGISTRATION WILL OPEN IN EARLY SPRING AT ANS.ORG

2017 Utility Working Conference and Vendor Technology Expo

Amelia Island, FL
August 6 – 9, 2017
REGISTRATION AND HOUSING WILL OPEN IN LATE FEBRUARY/EARLY MARCH AT ANS.ORG

2017 Nuclear Criticality Safety Division Topical Meeting

Carlsbad, NM
September 10 – 15, 2017
CHECK ANS.ORG FOR REGISTRATION & MORE INFORMATION



Hyatt Regency Jacksonville

Riverfront
 225 Coastline Drive East
 Jacksonville, Florida 32202
 Phone: 904-588-1234

DIRECTIONS

From Jacksonville International Airport, take I-95 south to exit 117, go east (left) on Union Street, then south (right) on Newnan and east (left) on Coastline.

From I-95 northbound, take exit 107 (Main Street/Prudential Drive) and follow signs to Main Street, go over the bridge onto Newnan Street, then left on Coastline.

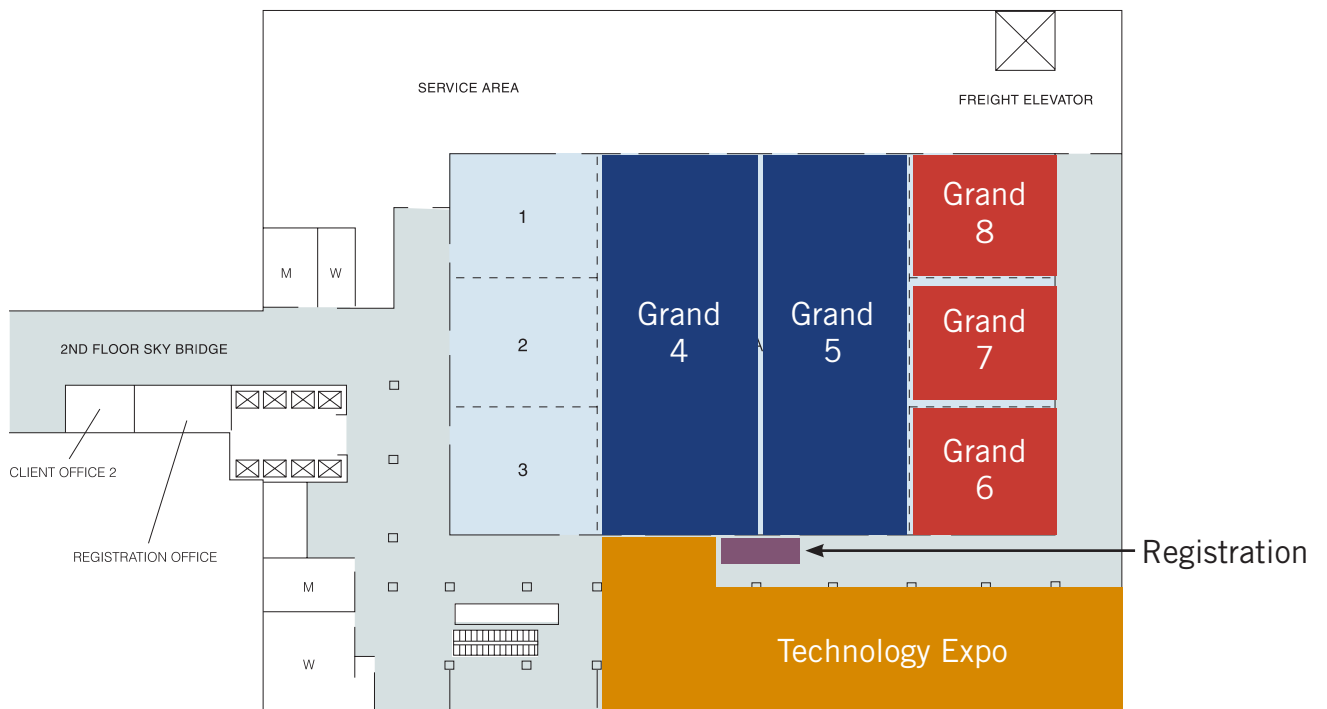

KEY

- CONTE Technical Sessions
- Plenary & Luncheon Room
- Registration
- Technology Expo/Breakfast/Breaks



ANS Conference

CONTE 2017

Conference on Nuclear Training and Education

A Biennial International Forum

February 5-8, 2017

Hyatt Regency Jacksonville Riverfront

Jacksonville, FL



American Nuclear Society
555 N. Kensington Ave.
La Grange Park, IL 60526
www.ans.org