



ANS Conference

Conference on Nuclear Training and Education

2017

Exhibitor and Sponsorship Prospectus

CONTE 2017

February 5-8, 2017

Hyatt Regency Jacksonville Riverfront

Jacksonville, FL





ANS Conference CONTE 2017

Vendor Technology Expo/Sponsorship Acknowledgement Form

February 5–8, 2017 | Jacksonville, FL, USA | Hyatt Regency Jacksonville Riverfront

Please complete the following information and send a copy of this form to: meetings@ans.org

Sponsorship acknowledgement form must be received by December 30, 2016.

Please list your company name, city & state as you would like it to appear in the preliminary program, PDF on ANS website, final program & signage throughout meeting.

Levels of Sponsorship (Please confirm your level of participation by checking the appropriate box to the left)

All sponsorship includes signage at the sponsored event or company logo on sponsored item and recognition in the program and entrance unit.

PLATINUM SPONSORSHIP: \$10,000 *Includes 4 conference registrations, (1) exhibit space, bag insert*

Choose one of the following options:

<input type="radio"/> Monday Lunch SOLD	<input type="radio"/> Monday Reception SOLD
<input type="radio"/> Tuesday Lunch SOLD	<input type="radio"/> Tuesday Reception SOLD
<input type="radio"/> Closing Luncheon	<input type="radio"/> Opening Reception SOLD

GOLD SPONSORSHIP: \$7,500 *Includes 3 conference registrations, (1) exhibit space*

Choose one of the following options:

<input type="radio"/> Badge holder/Lanyard SOLD	<input type="radio"/> Wednesday Breakfast
<input type="radio"/> Notepads	<input type="radio"/> Hotel Key Cards SOLD
<input type="radio"/> Monday Breakfast SOLD	<input type="radio"/> Conference Bags SOLD
<input type="radio"/> Tuesday Breakfast	

SILVER SPONSORSHIP: \$5,000 *Includes 2 conference registrations, (1) exhibit space*

Choose one of the following options:

<input type="radio"/> Monday Breaks SOLD	<input type="radio"/> Meeting Pens
<input type="radio"/> Tuesday Breaks	<input type="radio"/> 1/2 pg. ad in program SOLD
<input type="radio"/> Wednesday Breaks	<input type="radio"/> Bag Insert (2 available)
<input type="radio"/> Reusable Water Bottles SOLD	

BRONZE SPONSORSHIP: \$2,500 *Includes 1 conference registration, (1) exhibit space*

Note: Exhibit space not used by sponsor may not be donated.

Please Note: Additional meeting registrations must be purchased separately.

As an exhibitor or a conference sponsor, your company will be widely recognized by the organizers of the conference in the Preliminary Meeting Program (if acknowledgment of participation in the Vendor Technology Expo is received by Friday, October 21, 2016), on the ANS web site, in the Official Meeting Program and on recognition signs throughout the meeting and Vendor Technology Expo.

Each exhibit space includes

- one (1) 10' x 10' pipe and draped display area, one (1) 6' x 30" skirted table and two (2) chairs to display your company materials

Each meeting registration includes

- one (1) ticket for the Opening Reception, one (1) ticket for the Monday and Tuesday luncheons, daily continental breakfast and coffee breaks, admittance to technical sessions, and all available conference proceedings on CD Rom

Once payment has been received, you will receive instructions on how to register your complimentary attendees.

The reception, luncheons, daily continental breakfast and coffee breaks will be held in the exhibit area — the ideal forum for maximum interaction between vendors and conference attendees.

In order to guarantee your participation in the Conference on Nuclear Training and Education – CONTE 2017 as an exhibitor or a conference sponsor, payment in full, your completed contract and a brief description of your company's services or products is required by Friday, December 30, 2016.



ANS Conference CONTE 2017

Booth Selection

February 5–8, 2017 | Jacksonville, FL, USA | Hyatt Regency Jacksonville Riverfront

Please indicate three preferred booth locations in the Vendor Technology Expo. Booth assignments will be made on a first-come-first-served basis. Your preferred booth location cannot be guaranteed. ANS will contact you to confirm your booth assignment in the Vendor Technology Expo.

Floor Plan

EXHIBIT FLOOR IS CURRENTLY SOLD OUT!

Grand Ballroom Foyer

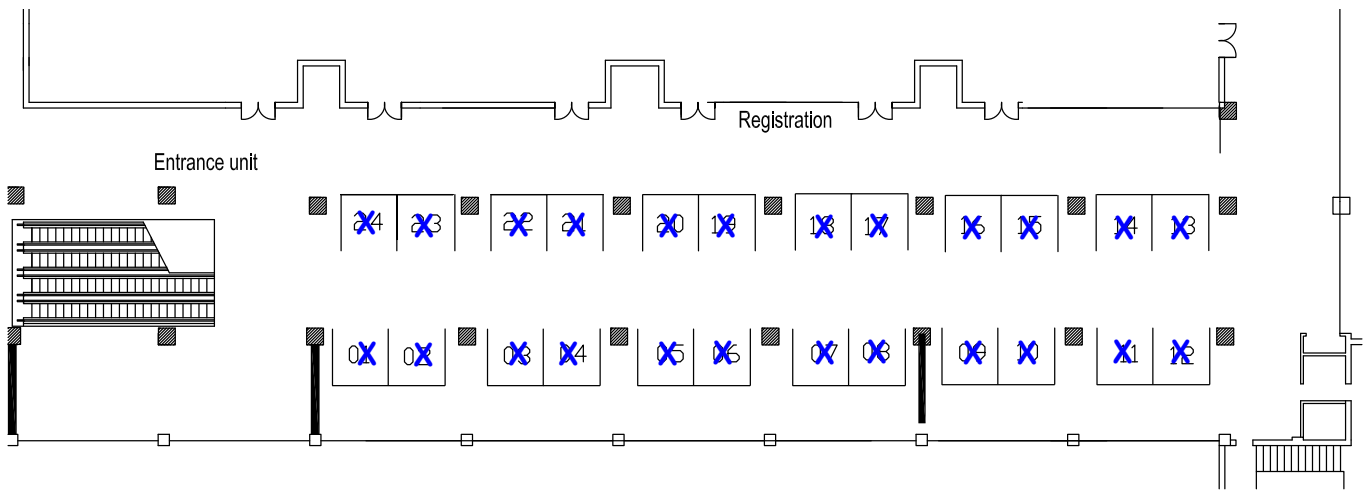

Booth Choice #1: _____ Booth Choice #2: _____ Booth Choice #3: _____

Please list any company that you do not want to be located near:

Please list any company that you would like to be in close proximity:



ANS Conference CONTE 2017

Vendor Technology Expo/Sponsorship Contract

February 5–8, 2017 | Jacksonville, FL, USA | Hyatt Regency Jacksonville Riverfront

The undersigned has agreed to provide sponsorship for, and/or exhibit at the ANS Conference on Nuclear Training and Education - CONTE 2017, February 5-8, 2017, and agrees to all terms and conditions on the reverse side of this contract.

Name of Organization: _____

Company Address: _____

Contact: _____

Phone: _____ Email: _____

I am an authorized representative of the Company with the full power and authority to sign and deliver this contract

Authorized Signature: _____

PAYMENT INFORMATION

- Platinum Sponsorship - \$10,000
- Gold Sponsorship - \$7,500
- Silver Sponsorship - \$5,000
- Bronze Sponsorship - \$2,500
- Additional Booth Space - \$2,500

Payment: (check one) Check VISA MasterCard American Express Diners Card

Credit Card No.: _____ Expiration Date: _____ Security Code: _____

Name of Cardholder (PLEASE PRINT): _____

Authorized Signature: _____

Please Return:

Please complete and return this contract along with full payment to: American Nuclear Society, 97781 Eagle Way, Chicago, IL 60678-9770; Attention: Meetings Department. You may choose to fax your contract with complete credit card information to the ANS Meetings Department at 708.579.8234 or return by email to meetings@ans.org

Terms and Conditions

- 1. General Event Information.** The event detailed on the front of this Contract ("Event") is being organized by the American Nuclear Society (ANS). The Event is conditioned upon the facility in which the Event is scheduled to be held ("Facility") making available the space during scheduled times. ANS makes no representations or warranties regarding the number of persons who will attend the Event. You, the Exhibitor (hereinafter "Exhibitor") agree to abide by the terms and conditions herein.
- 2. Application and Eligibility.** ANS reserves the absolute right to decline any application for space for any reason, if, in ANS's judgment, the products or services to be shown or demonstrated are not applicable to the stated purposes of ANS, are inconsistent with the stated purposes of ANS and the interests and welfare of its members, or are unreasonably duplicative of services or products offered by or available from. ANS further reserves the right in its sole discretion, to limit the types of companies and products represented at its Event, and accept or reject applications as it deems appropriate. Any cancellation or reduction of exhibit space made in writing by the exhibitor prior to December 19, 2016 will be refunded at 75% of the fees paid in advance. No refunds will be made after December 19, 2016.
- 3. Assignment and Use of Space.** ANS reserves the right to make and/or change all booth assignments as it deems appropriate. ANS reserves the right to restrict or prohibit any contest, promotion, lottery, or give-away that causes blocking or disturbance to other exhibitors or patrons or that could be considered illegal under the State laws where the exhibit is held. No Exhibitor shall assign, sublet, or share space allotted without prior written approval of ANS. All of the following practices are expressly prohibited: promotion of products and services other than those manufactured or regularly distributed by the Exhibitor; excessive noise that interferes with other Exhibitors; storage or use of flammable or explosive materials or any substance prohibited by local laws or insurance carriers; use of materials with strong odors; solicitation of business by anyone other than representative of Exhibitor; and promotion of any activities that draw Event Attendees or Corporate delegates away from the Event during show hours. The Exhibitor agrees not to utilize any displays which ANS determines, in its absolute discretion, would endanger the person or property of the attendees or of the Exhibitors, are in bad taste, are liable to discredit or subject ANS to criticism or legal liability, are inconsistent with the stated purposes of ANS and the interest and welfare of its members, are inimical to the property rights of ANS, or violate any other provision of this Contract. In the event ANS determines at any time that any display material may/or does violate this paragraph and the Exhibitor is unable or unwilling to cure or correct such violation, ANS may terminate this Agreement immediately and may remove or cause the display materials to be removed at Exhibitor's expense and Exhibitor hereby waives any claim for refund of the display materials or other damages arising out of such termination and/or display materials removal.
- 4. Display Materials.** Nothing shall be posted on, or tacked, nailed, screwed, or otherwise attached to the columns, walls, floors, or other parts of the building or furniture without permission from proper building authority. Packing, unpacking, and assembly of materials shall be done only in designated areas and in conformity with directions of the Event Manager, the Facility manager or their assistants. Anything necessary or proper for the protection of the building, equipment, or furniture will be at the expense of the Exhibitor. Exhibitors will be responsible for any damage to persons or property caused by reason of their displays, employees, agents or servants. Exhibitors agree to abide by all terms & conditions of Policies and Procedures as set forth by the Facility. Anything left by Exhibitor after the Event will be removed and destroyed by ANS. ANS/Viper reserves the right to determine what constitutes a "reasonable sight line." All booths, regardless of size or type, should be designed in such ways that eliminate line of sight obstructions from one exhibit to the next. Exhibitors are asked to take their neighboring exhibitors line of sight into consideration.
- 5. Event Hours, Setup, Breakdown.** Event hours will be established by ANS. ANS reserves the right to make changes to this schedule. No children under the age of 18 are allowed on the show floor during setup/breakdown, no exceptions. All booth personnel will need credentials, which allow access onto the trade show floor. Security will be checking badges and manning the entrance/exits of the expo at all times. Please note, any exhibitor who chooses to tear down early without preapproval from show management (any time prior to the designated teardown hours) will be subject to penalties. Penalties include: priority point(s) deduction and/or a fine.
- 6. Cancellation of Event.** If for any reason beyond ANS's reasonable control, including but not limited to strikes; labor disputes; acts, regulations or orders of governmental authorities; civil disorder; disasters; acts of war; acts of God; fires, flood, or other emergency conditions; any delay in necessary and essential repairs of the facility where the Event is to take place; ANS is unable to perform its obligations under this Contract, such non-performance is excused and such party may terminate this Contract without further liability of any nature, upon return of the Exhibitor's fees and deposit. Exhibitor further understands that ANS may in its sole discretion cancel the Event for reasons other than those stated above, in which case Exhibitor's sole remedy is a refund of any fees paid to ANS. In no event shall ANS be liable for consequential, indirect, special, incidental, punitive, or exemplary damages of any nature for any reasons whatsoever.
- 7. Insurance.** Exhibitor maintains sufficient liability insurance that covers all potential problems during the Event. Exhibitors are required to carry insurance to cover their property against damage and loss and public liability insurance for claims of injury to the person and property of others, including property owned by Facility, its owners or managers, which result from any act or omission of Exhibitor. In addition, Exhibitor acknowledges that neither ANS, nor the Facility, its owners, its operator maintain insurance covering Exhibitor's property and that it is the sole responsibility of Exhibitor to obtain business interruption and property damage insurance insuring any losses by Exhibitor.
- 8. Indemnity and Limitation of Liability.** Exhibitor shall be fully responsible to pay for any and all damages to property owned by Hyatt (Hyatt Regency Jacksonville Riverfront), its owners or managers which result from any act or omission of Exhibitor. Exhibitor agrees to defend, indemnify and hold harmless, ANS, Hyatt (Hyatt Regency Jacksonville Riverfront), its owners, managers, officers or directors, agents, employees, subsidiaries and affiliates, from damages or charges resulting from Exhibitor's use of the property. Exhibitor's liability shall include all losses, costs, damages, or expenses arising from, out of, or by reason of any accident or bodily injury or other occurrences to any person or persons, including the Exhibitor, its agents, employees, and business invitees which arise from or out of the Exhibitor's occupancy and use of the exhibition premises, the Hotel or any part thereof. Neither ANS nor the Facility shall be responsible for the security of Exhibitor's products, proprietary information or materials. Under no circumstances shall ANS, its agents, affiliates, employees or directors be liable for lost profits, or other indirect, incidental, consequential or exemplary damages in connection with the Event.
- 9. Shipping.** Shipping instructions will be forwarded to Exhibitor. Exhibitor will be solely responsible for arranging shipping and other services with the appropriate contractors and for payment of all fees, insurance tariffs, taxes and charges due for services rendered.
- 10. Photography.** No photographs or video shall be taken without the prior written consent of ANS. Exhibitor agrees that ANS may take photographs or video of Exhibitor's display, display materials and personnel for any promotional or marketing use by ANS.
- 11. Limited License.** Exhibitor grants to ANS the right to use and reproduce Exhibitor's names, trademarks and logos in connection with the promotion and production of the Event and for the purposes of this Contract.
- 12. Observance of Laws and Regulations.** Exhibitor shall abide by and observe any laws, rules, regulations, and ordinances, and all rules and regulations of ANS and the Facility in connection with its participation in the Event as may be set from time to time, including but not limited to those pertaining to public health and safety. Display materials must not block access doors to emergency fire exits. Exhibitor must observe all union regulations (if applicable) and electrical codes to which the Facility is subject. Special electrical, gas or water services, as well as other special services needed by individual Exhibitors, are provided only when the Exhibitor orders and agrees to pay for them from the supplier authorized to supply such services in conformity with Facility, insurance and other requirements.
- 13. Miscellaneous.** The Exhibitor expressly agrees to be bound by all the terms, conditions and specifications herein listed and by the Rules and Regulations established by ANS and as from time to time thereafter modified, and expressly agrees that this Contract and such Rules and Regulations contains the entire agreement between the parties hereto and supersedes any prior agreement, written or oral. This Contract shall be interpreted under the laws of the United States and the State of Illinois. Exhibitor understands and agrees that this Contract is subject to the terms of the Agreement between Facility Owner and ANS.
- 14. Reservation of Right to Make Changes.** Any matters not specifically covered herein are subject to decision by ANS. ANS reserves the right to make such changes, amendments and additions to these rules as considered advisable for the proper conduct of the exhibitor, with the provision that all exhibitors will be advised of any such change.



ANS Conference CONTE 2017

Release and Indemnity Agreement

February 5–8, 2017 | Jacksonville, FL, USA | Hyatt Regency Jacksonville Riverfront

In consideration of receiving permission from the American Nuclear Society to participate in and display their products at the meeting/event entitled, "2017 Conference on Nuclear Training and Education" and other good and valuable consideration, the sufficiency and receipt of which is hereby acknowledged, the undersigned hereby releases the American Nuclear Society, its agent, directors, officers, members, and employees of and from any and all liability, claims, demands, actions, and causes of action whatsoever, arising out of or related to any loss, damage, or injury, including death, that may be sustained by the undersigned, its agents, officers, members, and employees or invitees, while in attendance at the above mentioned meeting or upon any premises leased to, sanctioned by, or under the control or supervision of the American Nuclear Society.

In addition, the undersigned hereby agrees to indemnify and hold harmless the American Nuclear Society from any claim made or loss wwit may suffer in the future as a result of the participation of the undersigned, its agents, officers, members, and employees in the above mentioned meeting.

The undersigned further states that he/she has read and understands the foregoing release and indemnity agreement and is authorized to sign this release on behalf of his/her organization.

Hyatt Regency Jacksonville Riverfront
Jacksonville, FL
February 5-8, 2017

Signature

Company

Date



ANS Conference

CONTE 2017

Conference on Nuclear Training and Education

February 5-8, 2017

Hyatt Regency Jacksonville Riverfront

Jacksonville, FL



American Nuclear Society
555 N. Kensington Ave.
La Grange Park, IL 60526
www.ans.org